

S61120P

98.5-02 DODGE 2500/3500 5.9L CUMMINS, TURBO BACK, 5" SINGLE SIDE

MBRP

2-May-19

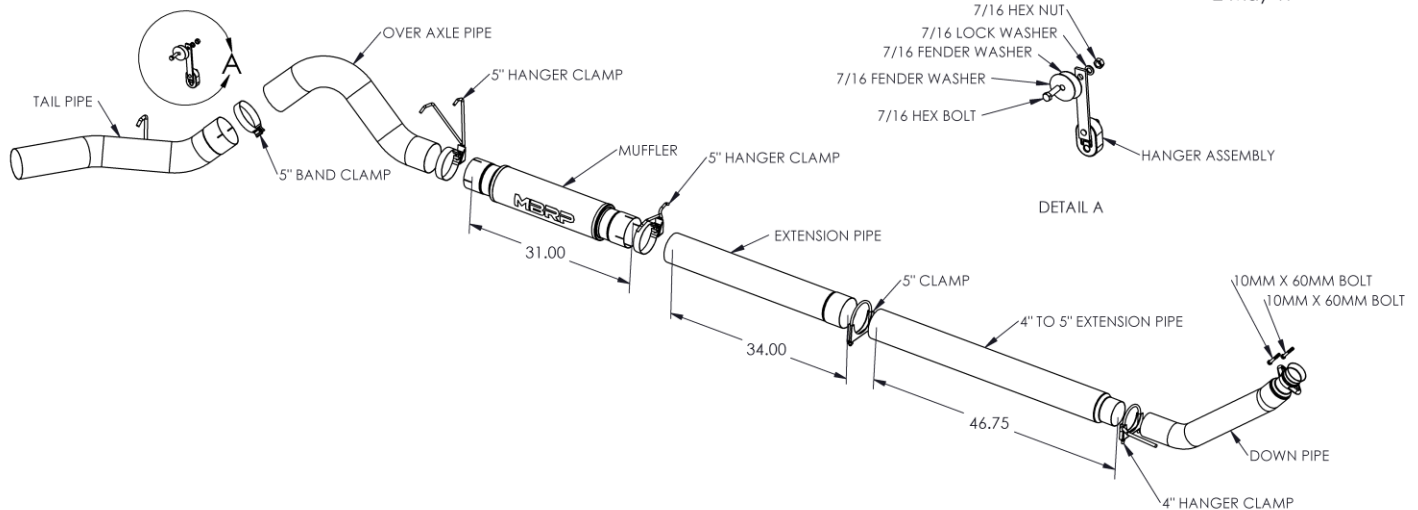

PLEASE READ BEFORE STARTING INSTALLATION

MBRP Inc. has made every effort to ensure that all components of this system are of superior quality and properly packaged. It is the installer's responsibility to ensure that all components are present and fit together as shown. Please also ensure that all components are undamaged before removal of the factory exhaust. Finally, check that this system properly matches the make and model of the vehicle and will not interfere with previous or planned modifications.

Removal of Stock System:

1. Separate the stock exhaust system at the slip joint by the muffler. Remove the exhaust from rubber hangers and remove the system from under the truck.
2. Using a socket or wrench, remove the two bolts at the turbo flange and remove the stock down pipe.

Installation of MBRP Performance Exhaust:

1. Install the **Down Pipe** in the same position as the stock down pipe placing the hanger into the OEM rubber insulator and attaching the flared end to the turbo using the supplied hardware. Do not fully tighten until all components are in place.
2. Install the **4" to 5" Extension Pipe** on to the **Down Pipe**. One of the Extension Pipes may require cutting to accommodate vehicles other than the **Quad Cab long bed**. (Installation tip: Temporarily hang the **Muffler** in place using the two OEM rubber hangers and measure from the **Muffler** to the **Down Pipe** to determine the length required.)
3. Install the **Muffler** over the **Extension Pipe** securing it with a **5" Hanger Clamp** and into the OEM rubber hangers above the inlet.
4. Install the **Tail Pipe** and **5" Band Clamp** onto the Over-Axle Pipe. From the rear of the truck, slide the assembly over the axle and attach to the outlet of the **Muffler** with the remaining **5" Hanger Clamp**. Now install the hangers into the OEM rubber hangers. (Note: 94-97 12 valve trucks may require rear hanger fabrication. Option: order a Rear Hanger Assembly HG6100)
5. Adjust the **Tail Pipe** and check along the whole length of the exhaust system to ensure there is adequate clearance around the fuel and brake lines or any wiring. If there is any interference detected, relocate or adjust.
6. Ensure that the exhaust is in place before tightening clamps. Start at the front of the exhaust system and tighten all connections.

Congratulations! You are ready to begin experiencing the improved performance and driving pleasure of your **MBRP** performance exhaust system. We know you will enjoy your purchase.